

**SECURITY STORM DOOR  
MODEL 2900 - 22 GAUGE MAIN FRAME**

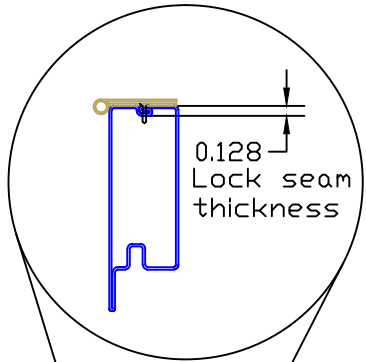

Hinge screw through lock seam

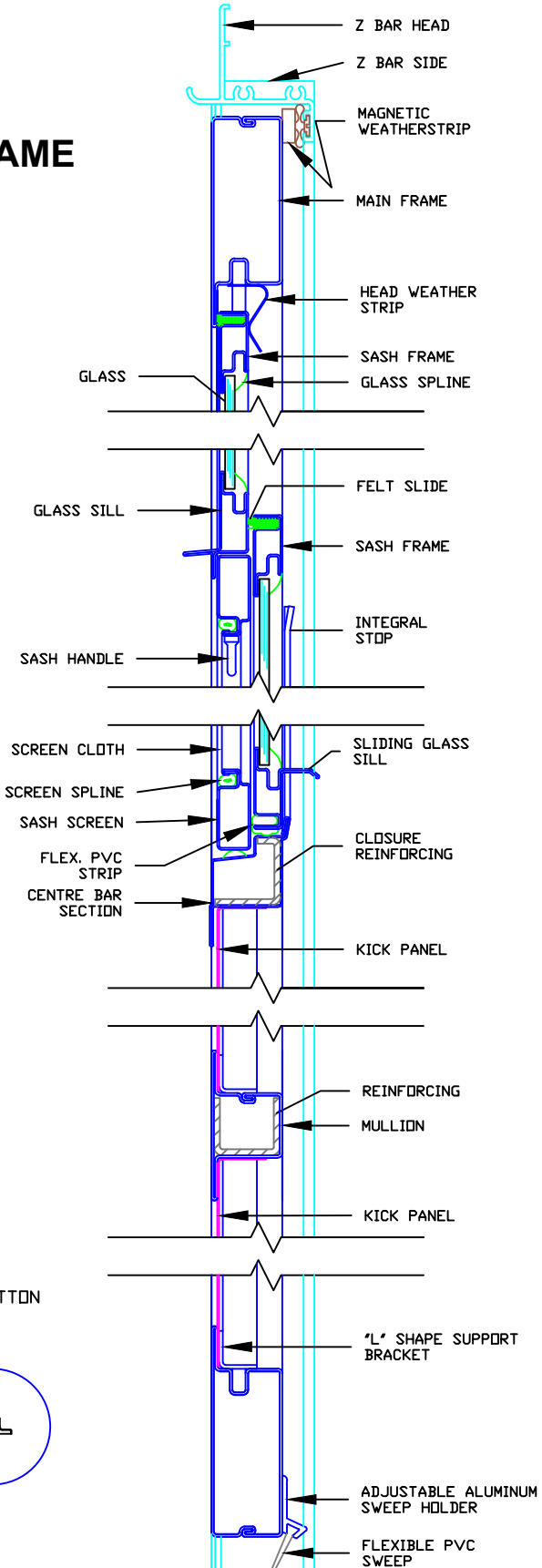
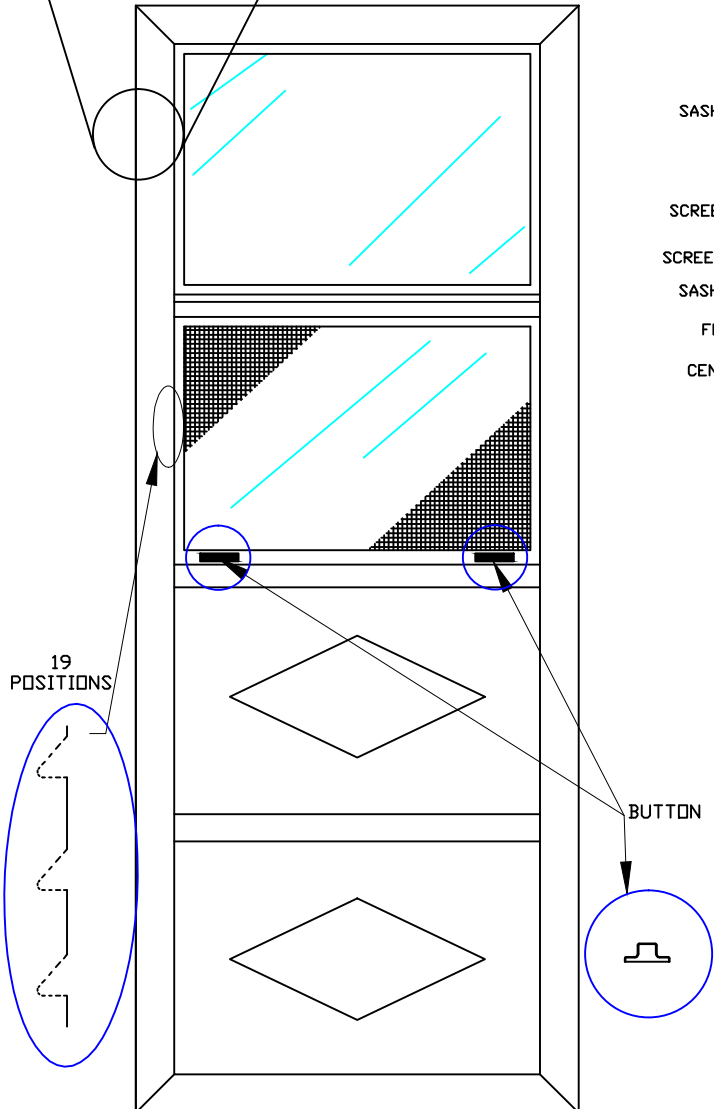

# **RUSCO**® MANUFACTURING INC. Specifications

## STEEL SECURITY STORM DOORS - PREHUNG Models 2700, 2800 & 2900

### GENERAL

---

- 1.1 Storm doors are used as an addition to the prime (main) door, introducing energy savings to the dwelling unit. Their use as a substitution for a prime door is not recommended.
- 1.2 Fabricate and supply storm doors complete with glazing, fly screens, weather-stripping, Z-bars, baked-on powder finish, fully assembled and pre-hung, ready for installation into prepared door openings.

### MATERIALS

---

- 2.1 Master frame shall be 22 gauge, mitered joint construction, not be less than 2-3/4" x 15/16" roll formed lock seam construction, internal corner reinforcing gussets of 16 gauge steel and edge brazed, G90 hot dipped galvanized steel.  
OPTION: 18 gauge main frame available as per drawing.
- 2.2 Glazing, screen spline and door sweep shall be made of polyvinyl plastic.
- 2.3 Weather-stripping shall be finest grade, resilient, water-repellent, mothproof wool felt, wool pile and/or polyvinyl plastic. Rigid and semi-rigid plastics shall be used with weather-stripping to prevent metal to metal contact.
- 2.4 Latch hardware, latch pin, knob and springs shall be made from corrosion resistant materials or finish.
- 2.5 Door shall consist of four hinges of 304 stainless steel leaf and pin, complete with oil lite bearings and sill sweep.  
SPECIAL NOTE: Hinges to be of tamper proof type, lefts and rights made of 304 stainless steel.  
OPTION: Dead lock - security lock (throw only, no key).
- 2.6 Glass shall be clear 3mm tempered float glass.
- 2.7 Screen cloth in standard screen insert shall be 16 x 18 mesh fibreglass  
OPTION: Standard insert available with aluminium or stainless steel wire cloth, 304 h .028 with a tensile strength of not less than 800 pounds, or .023 pet screen.
- 2.8 Kick panel shall be 18 gauge galvanized steel, diamond embossed for rigidity (also available in 16 gauge), Model #2800 raised 2 panel as per drawing.

**STEEL SECURITY STORM DOORS - PREHUNG  
Models 2700, 2800 & 2900****MATERIALS (continued)**

---

- 2.9 Frame liner (Z-bar) shall be .062 aluminum.  
Head liner to contain weather-stripping and built-in drip cap over the door  
Jamb liner (latch side) to contain weather-stripping  
Jamb liner (hinge side) to contain flexible bulb vinyl weather-stripping.  
OPTION: Magnetic weather-stripping is available.
- 2.10 Fastenings to be cadmium or zinc plated screws.
- 2.11 Adjustable sill sweep shall be of extruded aluminum with flexible vinyl sweep.  
OPTION: Adjustable Box Sweep is also available; Box sweep shall consist of an extruded aluminum box sweep. The aluminum used will be 6105-T5 Aluminum alloy (which is 133% stronger than 606-T5 aluminum). Complete with two flexible SANTOPRENE RUBBER sweeps.

**CONSTRUCTION**

---

- 3.1 Master frame sections shall be mitered joint construction, not be less than 2 ¾" x 15/16" roll formed lock seam construction, internal corner reinforcing gussets of 16 gauge steel and edge brazed.
- 3.2 Transom rail shall be notched, suitably reinforced and brazed to the jamb rails at both sides.
- 3.3 Glass inserts shall be of mitered joint construction and brazed at all exterior corners.
- 3.4 Screen inserts shall be of mitered joint construction brazed at all exterior corners.
- 3.5 Frame liners (Z-bars) to have all installation holes pre-punched and hinges attached.

**RUSCO® MANUFACTURING INC. Specifications****STEEL SECURITY STORM DOORS - PREHUNG  
Models 2700, 2800 & 2900****CONSTRUCTION (continued)**

---

- 3.6 Upper glass inserts shall be held in place by a continuous steel head weather-strip retainer, resting on the integral stop.

Lower glass inserts in all storm doors, shall be held in place by spring activated self-locking latch pins and adjustable to 3 positions.

Standard screen inserts in series 2700, 2800 and 2900 doors are 24 gauge self-storing and are located in line (under) with upper glass inserts.

- 3.7 All glass and screen inserts are replaceable without special tools within their series, providing door size and colors are compatible.
- 3.8 KT 186 heavy duty hardware kits with Rusco black security installation screws are supplied from manufacturer.

**FINISH**

---

- 4.1 All metal parts formed from G90 hot dipped galvanized steel shall be chemically pre-treated to insure proper paint adherence. All aluminum liners (Z-bars) shall receive one coat of baked on prime. All materials shall be finished with electrostatic powder coating, followed by a baking for 20 minutes at 350°F. Color to be selected from manufacturer's standard color range.  
OPTION: Custom colors available to match architectural requirements

**GLAZING**

---

- 5.1 All glass shall be bedded in approved sealants and held in place with removable reusable, laid-in glazing spline.

**SCREENING**

---

- 6.1 Screen inserts with fibreglass and aluminum cloth shall be held in place with removable, reusable, rolled in glazing splines.

**PACKAGING**

---

- 7.1 Doors will be carefully packaged using cardboard edge liners and wrapped in poly bags.

**RUSCO<sup>®</sup> MANUFACTURING INC.** **Specifications**

**STEEL SECURITY STORM DOORS - PREHUNG  
Models 2700, 2800 & 2900**

**INSTALLATION**

---

- 8.1 Verify that the door openings are satisfactory and ready to accept pre-hung storm doors.
- 8.2 The installer shall securely fasten doors to place in a straight, plumb and level condition, without distortion of the door or door frame and shall make final adjustments for proper operation and satisfactory weathering contact and seal in accordance with manufacturer's instructions.
- 8.3 Clean up properly as the work proceeds and on completion clean up glass surfaces, touch up marred enamelled surfaces, remove all protective materials and dispose of all rubbish and surplus materials resulting from the foregoing work.

**WARRANTY**

---

The entire door, including inserts but exclusive of screening material and glass shall be guaranteed for a period of one (1) year from date of delivery to the site. The guarantee shall cover the entire door against defects in design, material and workmanship. The contractor shall agree to furnish, free of charge, F.O.B ordering agency any part or parts which must be a design that will permit installation readily and not require special tools. The contractor agrees to furnish, free of charge, a complete replacement door F.O.B ordering agency when the defective part or parts cannot be readily installed without the use of special tools.

It is understood that all replacements shall be made by the contractor and ordering agency will not negotiate with any other party other than the contractor to obtain replacements.

The following exceptions shall apply to said warranty:

- 1. Normal wear and tear
- 2. Uniform fading of colors
- 3. Improper maintenance
- 4. Abuse and carelessness

## RUSCO SCREEN DOOR AND STORM DOOR INSTALLATION INSTRUCTIONS

### WOOD B/M

1. Measure height of jamb on brickmould (latch and hinge sides)
2. Cut Z-bar to length on jamb sides.
3. Set door in opening and start by fastening hinge side first. Fasten through installation holes in face of Z-bar and next set gap at header and fasten (GAP 1/8" approximately). Remove shipping clips from latch sides and fasten. Screws should be 1 ¼ #8 Pan Head Robertson.
4. Fasten Z-bar through the hinge port left open in the stainless steel hinge with a screw long enough to secure the hinge side of the Z-bar from the inside.
5. Install storm door handle with screws provided and screw bottom of outside handle.
6. Mount closure bracket in line with mullion above the bottom kick panel, and fasten with screws provided in the hardware kit. Join closure to bracket using pin and pull closure to extend ½" and lock in place with lock ring. Fasten closure to door.
7. Fasten wind chain to top of door. Open door to just under 90°, and lock closer so you fasten other end of wind chain to header of frame using screws provided. (Be sure to hold chain tight but do not compress spring). Next, fasten spring to chain at centre link, and screw the other end of chain to the header to hold the chain up (fasten towards hinge side).
8. Set sweep at bottom of door and fasten with #8 x 1/2 " Pan Head Robertson screws. (Sweep should be touching sill by approximately 1/8"). Sweep to be installed on the exterior of the door.

### STEEL B/M

1. Measure the height of the jamb on brickmould (latch and hinge sides)
2. Cut Z-bar to length on jamb sides.
3. Set door in opening and start by fastening hinge side first. Fasten through installation holes in face of Z-bar and next set gap at header and fasten (GAP 1/8 approximately). Remove shipping clips from latch side and fasten. Screws should be 3/4" #8 self-drilling Pan Head Robertson.
4. Fasten Z-bar through the hinge port left open in the stainless steel hinge, with a screw long enough to secure the hinge side of the Z-bar from the inside.
5. Install storm door handle with screws provided and screw bottom of outside handle.
6. Mount closure bracket in line with mullion above the bottom kick panel, and fasten with screws provided in the hardware kit. Join closure to bracket using pin and pull closure to extend ½" and lock in place with lock ring. Fasten closure to door.
7. Fasten wind chain to top of door. Open door to just under 90° and lock closer so you can fasten the other end of wind chain to header of frame using screws provided. (Be sure to hold chain tight but do not compress spring). Next, fasten spring to chain at centre link, and screw the other end of chain to the header to hold the chain up (fasten towards hinge side).
8. Set sweep at bottom of door and fasten with #8 x 1/2" Pan Head Robertson screws. (Sweep should be touching sill by approximately 1/8"). Sweep to be installed on the exterior of the door.

**RUSCO**® MANUFACTURING INC.

**Specifications**

**CLEANING AND CARING FOR  
YOUR NEW RUSCO STEEL SCREEN OR STORM DOOR**

**STEP ONE**

---

Wash door and steel frame with a mild non-abrasive soap and soft cloth.

**STEP TWO**

---

Rinse door and frame with water and dry with chamois, making sure there are no water spots.

**STEP THREE**

---

Apply a good car wax as directed by wax manufacturer. Use a wax that is recommended to be done no more than twice per year.