

**RUSCO® MANUFACTURING INC.**  
**SECURITY SCREEN DOOR**  
**MODEL 1700 - 22 GAUGE MAIN FRAME**

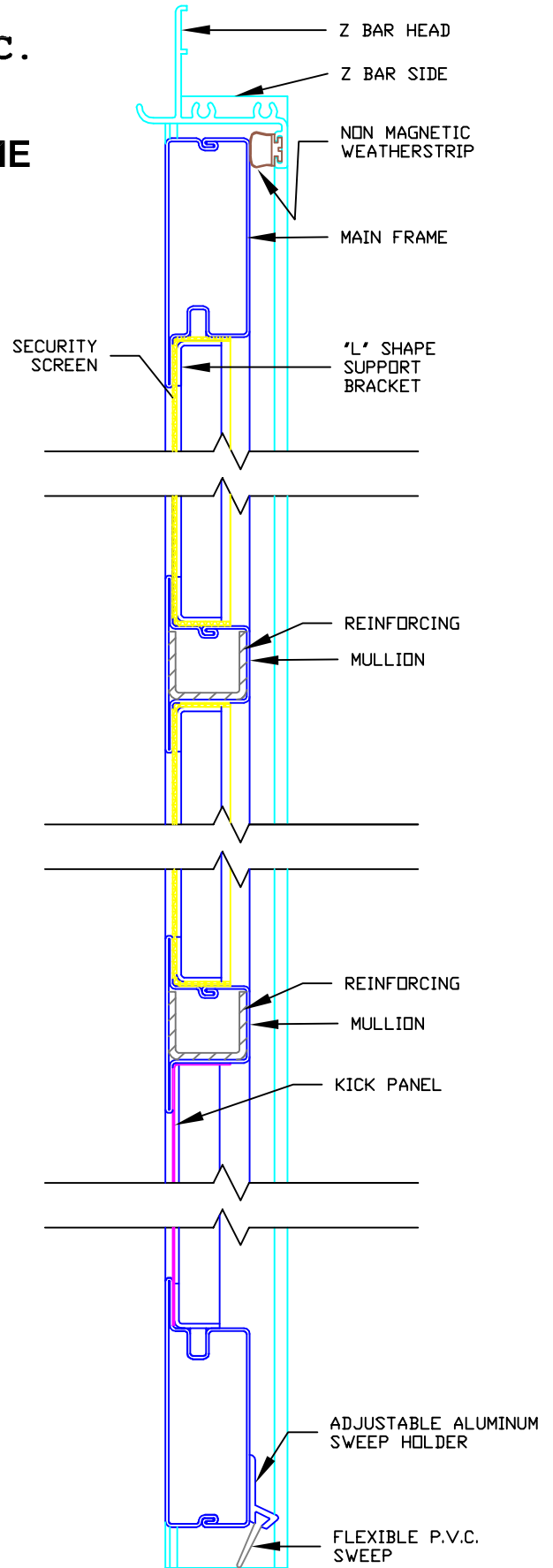
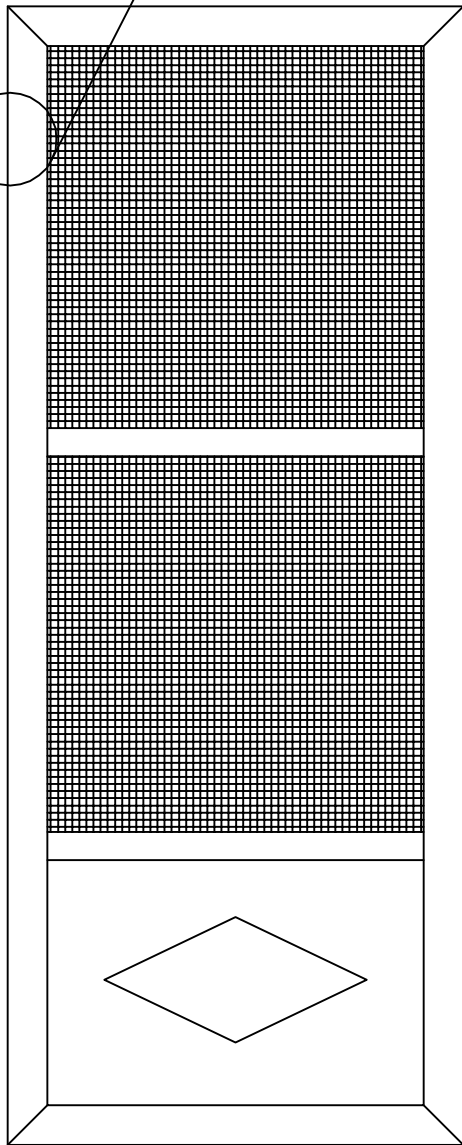
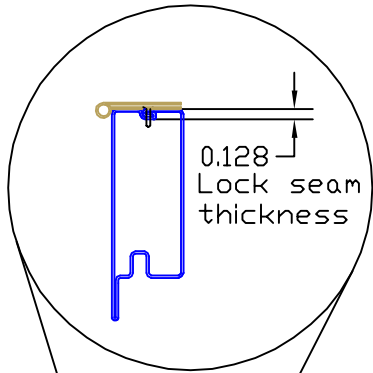

# **RUSCO** MANUFACTURING INC. Specifications

## STEEL SECURITY SCREEN DOORS MODEL # 1700, 1800 & 1900

### GENERAL

---

- 1.1 Stainless steel security screen doors must be tested by a recognized testing laboratory to conform to SMA 6001-2002 "Proposed American National Standard Specifications for Metal Protection Screens"
- 1.2 Stainless steel security doors shall be furnished complete with magnetic and/or compression type weather-stripping, sill sweep and be pre-hung in an aluminum Z-bar frame ready for installation.

### MATERIALS

---

- 2.1 Master frame shall be 22 gauge, G90 hot dipped galvanized steel, roll formed lock seam construction.
- 2.2 Kick panel shall be 18 gauge galvanized steel, embossed for rigidity (also available in 16 gauge).
- 2.3 Z-bar frame liners shall be of extruded aluminum and utilize magnetic and/or compression type flexible vinyl weather-stripping on head and both jambs. (Z-bar header with drip cap).
- 2.4 Stainless steel marine grade screen cloth to be 304 h alloy .028 inch diameter wire, 12 x 12 mesh with a tensile strength not less than 800 pounds per linear inch after weaving.
- 2.5 Fastenings to be cadmium or zinc plated steel screws.
- 2.6 Adjustable sill sweep shall be of extruded aluminum with flexible vinyl sweep.  
(See options section page 2).

# **RUSCO** MANUFACTURING INC. Specifications

## STEEL SECURITY SCREEN DOORS MODEL # 1700, 1800 & 1900

### CONSTRUCTION

---

- 3.1 Main frame sections shall be mitered joint construction, not be less than 2 ¾" x 15/16" roll formed lock seam construction, internal corner reinforcing gussets of 16 gauge steel and edge brazed.
- 3.2 Transom and mullions to be brazed to master frame.
- 3.3 For added security, mullion rails may be used to separate two or more wire mesh sections, 18 gauge reinforcing is added to mullion in hardware application.
- 3.4 Kick panels to be held in place with continuous steel stops and cadmium plated screws.
- 3.5 Wire mesh screening shall have a 90 degree bend minimum ½ inch on all four sides and be held in place with 18 gauge continuous steel retainer angle applied with Rusco tamper proof screws 4 inch on center to discourage easy removal.
- 3.6 Doors to be hung in a pre-punched aluminum Z-bar using four tampered proof 302 or 304 stainless steel hinges, left or right (leaf and pin non removable pin) with oil lite bearings. Frames to be installed onto existing frame using cadmium or zinc plated steel screws.

### OPTIONS

---

Z Bars shall be installed in existing frame using Rusco steel tamper proof security screws which require a special tool for removal to discourage vandalism and theft.

KT 186 Heavy Duty Hardware Kits with Rusco black security installation screws are available from manufacturer.

Adjustable box sweep is also available. Box sweep shall consist of an extruded aluminum box sweep. The aluminum used will be 6105-T5 Aluminum alloy (which is 133% stronger than 6063-T5 aluminum). Complete with two flexible SANTOPRENE RUBBER Sweeps.

Model 1800 door is available with raised 18 gauge steel embossed kick panel.

# **RUSCO<sup>®</sup> MANUFACTURING INC.** **Specifications**

## **STEEL SECURITY SCREEN DOORS MODEL # 1700, 1800 & 1900**

### **FINISH**

---

- 4.1 All steel sections will be chemically pre- treated to ensure proper paint adherence.
- 4.2 All exposed surfaces of the door, wire mesh, aluminum Z-Bar and aluminum sweep shall be finished with polyester powder paint, electro statically applied and baked for a total of 20 minutes at 350°F. Colors to be selected from manufacturer's standard color range.

OPTION: Special colors available to match architectural requirements.

### **PACKING**

---

- 5.1 Doors will be carefully packaged using cardboard edge liners.

### **INSTALLATION**

---

- 6.1 Verify that door openings are satisfactory and ready to accept pre-hung screen door.
- 6.2 The installer shall securely fasten doors in place in a straight, plumb and level condition without distortion of the door or door frame, and shall make final adjustments for proper operation and satisfactory weathering contact and seal in accordance with manufacturers instructions.
- 6.3 Clean up properly as the work proceeds and on completion, touch up any marred enameled surfaces, remove all protective materials and dispose of all rubbish and surplus materials resulting from the foregoing work.

**RUSCO**® **MANUFACTURING INC.** **Specifications**  
**STEEL SECURITY SCREEN DOORS**  
**MODEL # 1700, 1800 & 1900**

**WARRANTY**

---

The entire door shall be guaranteed for a period of one (1) year from the date of delivery to the site. The guarantee shall cover the entire door against defects in design, material and workmanship. The contractor shall agree to furnish, free of charge, F.O.B ordering agency any part or parts which must be of a design that will permit installation readily and not require special tools. The contractor shall agree to furnish, free of charge, a complete replacement door, F.O.B ordering agency, when the defective part of parts cannot be readily installed without the use of special tools.

It is understood that all replacements shall be made by the contractor and the ordering agency will not negotiate with any party of than the contractor to obtain replacements.

The following exceptions shall apply to said warranty:

1. Normal wear and tear
2. Uniform fading of color
3. Improper maintenance
4. Abuse and carelessness

## RUSCO SCREEN DOOR AND STORM DOOR INSTALLATION INSTRUCTIONS

### WOOD B/M

1. Measure height of jamb on brickmould (latch and hinge sides)
2. Cut Z-bar to length on jamb sides.
3. Set door in opening and start by fastening hinge side first. Fasten through installation holes in face of Z-bar and next set gap at header and fasten (GAP 1/8" approximately). Remove shipping clips from latch sides and fasten. Screws should be 1 ¼ #8 Pan Head Robertson.
4. Fasten Z-bar through the hinge port left open in the stainless steel hinge with a screw long enough to secure the hinge side of the Z-bar from the inside.
5. Install storm door handle with screws provided and screw bottom of outside handle.
6. Mount closure bracket in line with mullion above the bottom kick panel, and fasten with screws provided in the hardware kit. Join closure to bracket using pin and pull closure to extend ½" and lock in place with lock ring. Fasten closure to door.
7. Fasten wind chain to top of door. Open door to just under 90°, and lock closer so you fasten other end of wind chain to header of frame using screws provided. (Be sure to hold chain tight but do not compress spring). Next, fasten spring to chain at centre link, and screw the other end of chain to the header to hold the chain up (fasten towards hinge side).
8. Set sweep at bottom of door and fasten with #8 x 1/2 " Pan Head Robertson screws. (Sweep should be touching sill by approximately 1/8"). Sweep to be installed on the exterior of the door.

### STEEL B/M

1. Measure the height of the jamb on brickmould (latch and hinge sides)
2. Cut Z-bar to length on jamb sides.
3. Set door in opening and start by fastening hinge side first. Fasten through installation holes in face of Z-bar and next set gap at header and fasten (GAP 1/8 approximately). Remove shipping clips from latch side and fasten. Screws should be 3/4" #8 self-drilling Pan Head Robertson.
4. Fasten Z-bar through the hinge port left open in the stainless steel hinge, with a screw long enough to secure the hinge side of the Z-bar from the inside.
5. Install storm door handle with screws provided and screw bottom of outside handle.
6. Mount closure bracket in line with mullion above the bottom kick panel, and fasten with screws provided in the hardware kit. Join closure to bracket using pin and pull closure to extend ½" and lock in place with lock ring. Fasten closure to door.
7. Fasten wind chain to top of door. Open door to just under 90° and lock closer so you can fasten the other end of wind chain to header of frame using screws provided. (Be sure to hold chain tight but do not compress spring). Next, fasten spring to chain at centre link, and screw the other end of chain to the header to hold the chain up (fasten towards hinge side).
8. Set sweep at bottom of door and fasten with #8 x 1/2" Pan Head Robertson screws. (Sweep should be touching sill by approximately 1/8"). Sweep to be installed on the exterior of the door.

**RUSCO**® MANUFACTURING INC.

**Specifications**

**CLEANING AND CARING FOR  
YOUR NEW RUSCO STEEL SCREEN OR STORM DOOR**

**STEP ONE**

---

Wash door and steel frame with a mild non-abrasive soap and soft cloth.

**STEP TWO**

---

Rinse door and frame with water and dry with chamois, making sure there are no water spots.

**STEP THREE**

---

Apply a good car wax as directed by wax manufacturer. Use a wax that is recommended to be done no more than twice per year.